

Installation Notes for the

Thermomax Mazdon System

THERMOMAX DIVISION

THERMO TECHNOLOGIES

January 2004

5560 Sterrett Place, Suite 115
Columbia, MD 21044
E-mail: info@thermotechs.com
Internet Site <http://www.thermotechs.com>
Phone (410) 997-0778 o fax (410) 997-0779

CAUTIONS

We advise you to read through this guide for technical details and installation data before commencing with the installation.

1. Gloves and eye protection must be used when handling glass tubes.
2. Avoid scratching or sudden shock to tubes.
3. Unpack and install tubes only after the manifold unit has been installed and all the pipe work has been completed.
4. The Chloride content of the water passing through the manifold should not exceed 40ppm.
5. In hot water applications a heat exchanger should be used between the collector and the hot water storage tank to ensure a long and trouble free service life.
6. When heating a swimming pool or spa a heat exchanger must be used between the pool and the collector.
7. Thermomax manifold systems are designed to operate at a maximum pressure of 5bar (75psi) it is strongly recommended to use a relief valve (set at 4.5bar).
8. To prevent corrosion and scaling we would recommend using a corrosion inhibitor in the system.
9. The circulating pump should under no circumstances be switched off during a sunny day. If switched off, there will be a high temperature and as a result, high pressure in the system. When not in use for extended periods, the circulating pump must be left switched on and a by-pass should divert the heat from the storage tank.
10. The Thermomax tubes should under no circumstances be exposed to the sun for extended periods (maximum one day) if the system has not been filled.
11. ALL LOCAL AUTHOURITIES REGULATIONS AND REVELANT STANDARDS SHOULD BE FOLLOWED.

M SYSTEM INSTALLATION GUIDE

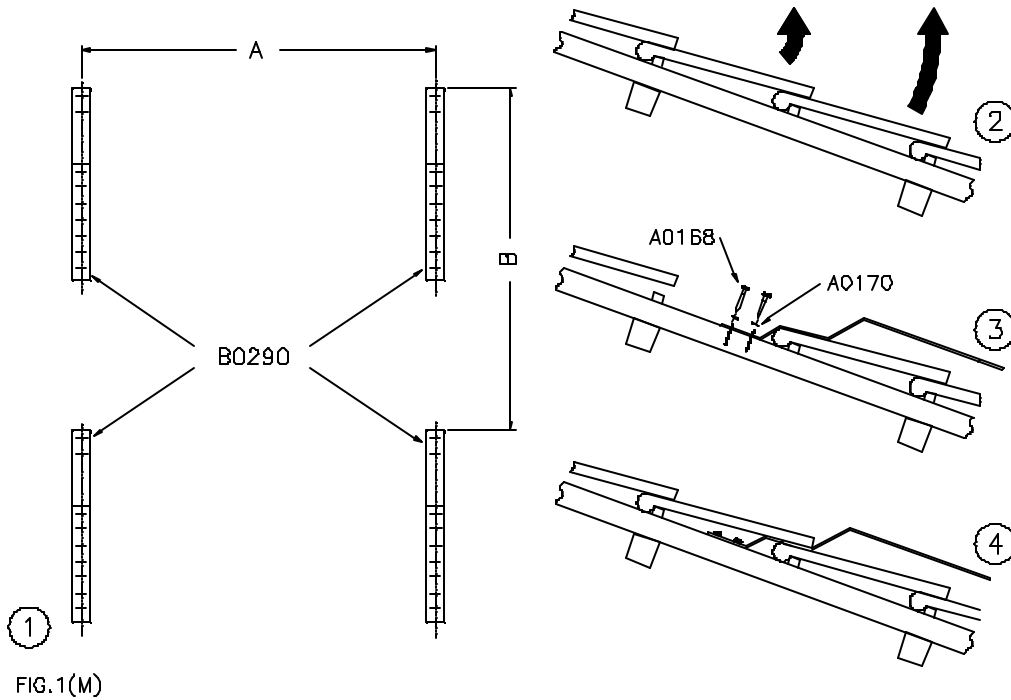

1. Select a suitable position for the collector. It should face due south. Recommended angle of tilt is the same as the geographical latitude. Distances between the perforated bands are given in Table 1.
2. Remove tiles as per FIG.1(M) (2).
3. Secure the LOWER band (Pt. No. B0290) to rafter using coach screws (Pt. No. A0168 / A0170). [FIG.1(M) (3)]
4. Replace tiles. [FIG.1(M) (4)] .

Table 1: Distance between the side rails

		System Type	
		MAZ 20 - 2	MAZ 30 - 2
Measurement	A	35" - 48"	48" - 55"
	B	55"	

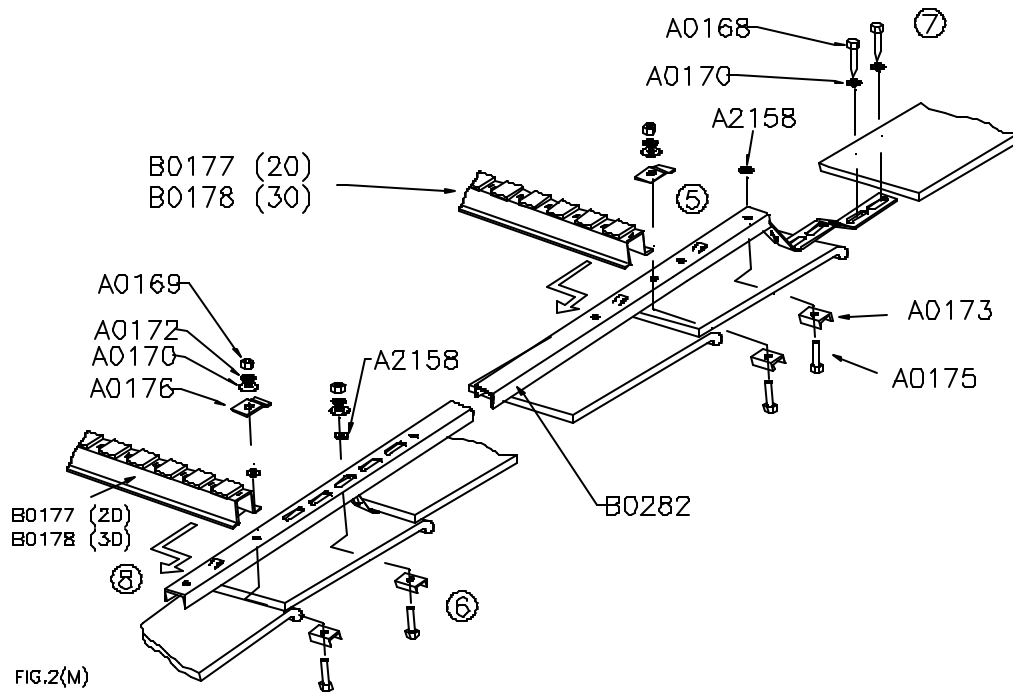

5. Locate and secure the UPPER band to the top end of the side rail (Pt. No. B0282) using the lower hole. Use the Nylon washer (Pt. No. A2158) to hold the bolt of the lowest hole in place for later use. Remove upper tiles.
6. Locate and secure end of the side rail (Pt. No. B0282) to the LOWER band using the middle hole in the side rail. Use the Nylon washer (Pt. No. A2158) to hold the bolt in place for later use.
7. Secure UPPER band to rafter. [FIG.2(M) (7)]
8. Locate and secure support rails (Pt. No. B0177 (20) / B0178 (30)) to the side rails [FIG.2(M) (6)] and [FIG.2(M) (8)]

Note: This process (steps 2 to 7) should be repeated for the opposite side of the frame.

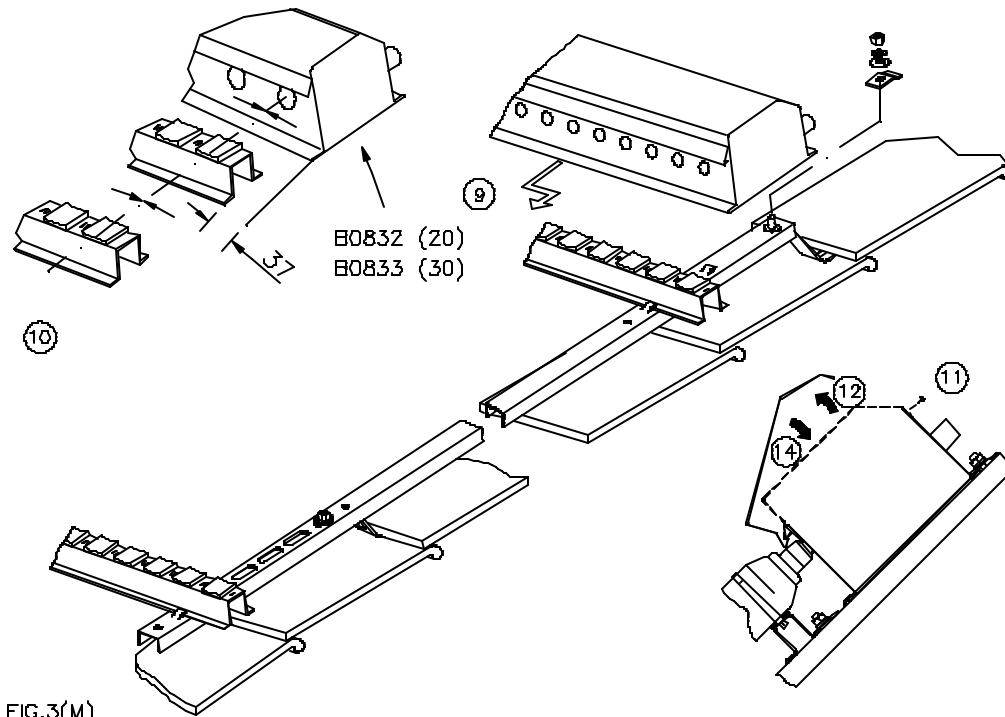
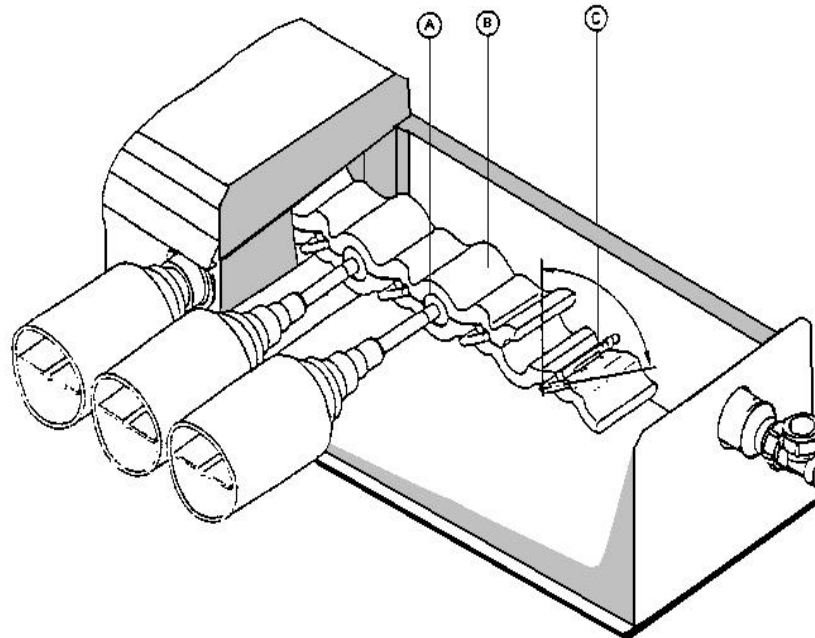

FIG.3(M)

9. Locate manifold (Pt. No. B0832 (20) / B0833 (30)) in tab at top of side rails and bolt as shown. The distance from the side rails to the ends of the manifold should be equal. [FIG.3(M) (9)]
10. Ensure that both support rails and manifold are in line (centre line of rubber support pads with centre line of holes in manifold) [FIG.3(M) (10)]. Tighten all bolts.
11. Locate manifold fittings to manifold inlet and outlet. Note that the air vent should be installed vertically. Check all plumbing and pipe work between collector and hot water storage tank. Fill the system, switch the circulating pump on and vent the installation.
12. Remove the self-tapping screws [FIG.3(M) (11)] and remove the manifold lid. [FIG.3(M) (12)]
13. Switch on circulating pump.
14. Make sure there is no leak in piping system.
15. Check system pressure and flow rate.



- (A) With the supplied Stainless steel tube (Key Lever) open the pocket in the manifold chamber "B" by turning the Key Level "C" through 90°. Unpack the first tube; insert condenser "A" gently through grommet in front of the manifold. Resting the tube body on the rubber pads of the top and bottom support rails, slide the condenser "A" into the open pocket. **ENSURE BLACK SURFACE OF ABSORBER FACES UPPERMOST AND TOWARDS THE SOUTH.**
- (B) Make sure the tube condenser is exactly between the two copper blocks and sits evenly through hole in manifold chamber.
- (C) Repeat stages (A) and (B) for all tubes. Secure tubes by turning the Key Lever to original position.

16. Replace manifold's lid and secure with self-tapping screws.

17. Make the final inspection on each tube.

18. Set clips over tubes to both top and bottom support rails.

19. Ground manifold installation as per local government regulations and switch pump control unit to automatic

The manifold flows and return connections are 3/4" copper pipes. Two compression couplings are included in each manifold system. These couplings are to be used. **Manifold inlet and outlet should not be soldered.**

System Operation and Plumbing Details

The interconnections of the manifolds, pumps, valves, and pipes shall meet the recommendations required by manufacturer's installation manual books. Great care must be taken to ensure long-term durability and leak tightness of the interconnection and piping. The typical closed loop interconnection for the Thermomax solar collectors is shown in the following diagram:

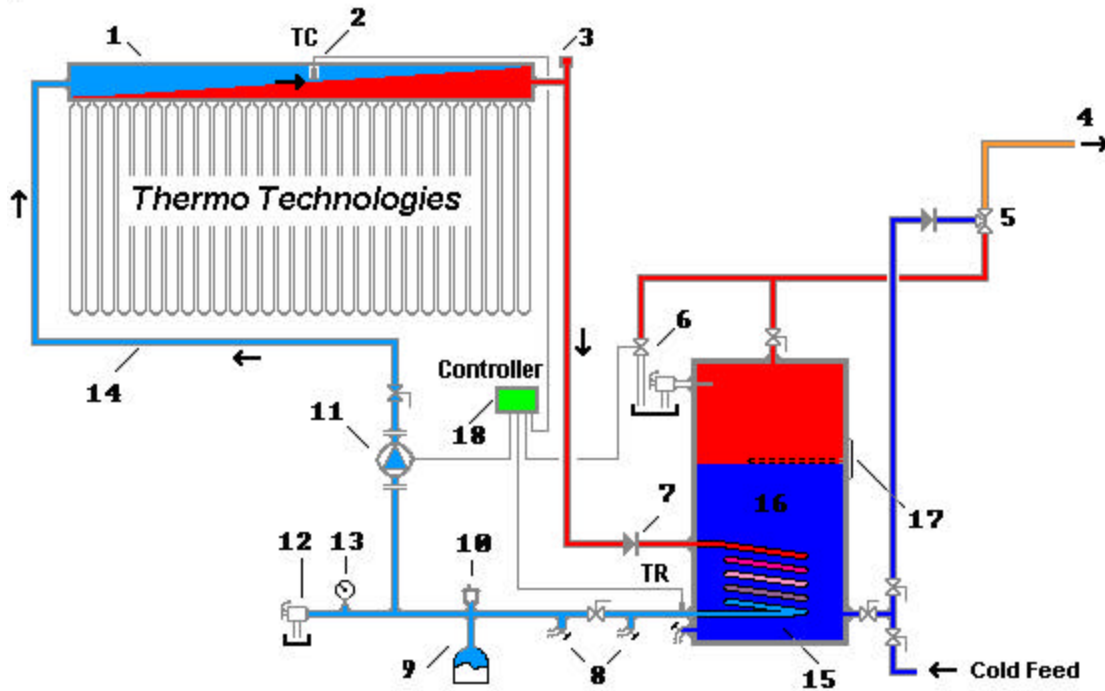

- | | | |
|-------------------------------|---------------------------------------|--------------------------|
| 1. Collector | 7. Check Valve (Optional) | 13. Pressure Gauge |
| 2. Collector Sensor | 8. Hose Bibs for Filling and Flushing | 14. Collector Supply |
| 3. Manual Air Valve | 9. Expansion Tank | 15. Heat Exchange Coil |
| 4. Hot Water to Existing Tank | 10. Air Purge and Air Vent | 16. Solar Hot Water Tank |
| 5. Tempering Valve | 11. Circulating Pump | 17. Immersion Heater |
| 6. Solenoid Valve (Optional) | 12. Pressure Relief Valve | 18. Solar Controller |

- The Control System will switch on the pump when the temperature at the collector sensor TC is higher than the return temperature TR by at least the pre-selected amount.
- The pump circulates heat transfer liquid around the loop.
- Heat from the collector is transferred to the storage tank.
- Solenoid valve (6) discharges hot water if the tank temperature is reached at T_{MAX} (vacation or low hot water usage system protection).

When a pre-set tank temperature is reached at T_{MAX} , the solar controller system switches off the pump. The check valve (non-return valve) prevents heat from the tank rising towards the collector should the tank be warmer (e.g. at night).